

Inspection Date: 2026-01-04
 Batch Quantity: 1012 Pcs
 Inspector Quantity: 3 Pcs
 Batch No.: 20260104

Specification: 2400*4000*5.6mm
 Customer#: BDGF
 Order No.: 20260104
 Inspection Basis: MT/T 146.1-2011

I. Physical Inspection

	Appearance	Diameter	Length
Standard	Visually check other obvious defects eg. sharp edges, twisted or bent etc.	5.6 mm	4000mm
Tolerance	/	±0.05	(+0/-10mm)
Inspection Results	Meet standard requirements	5.6;5.59;5.61	2998;2998;
Conclusion	Qualified	Qualified	Qualified

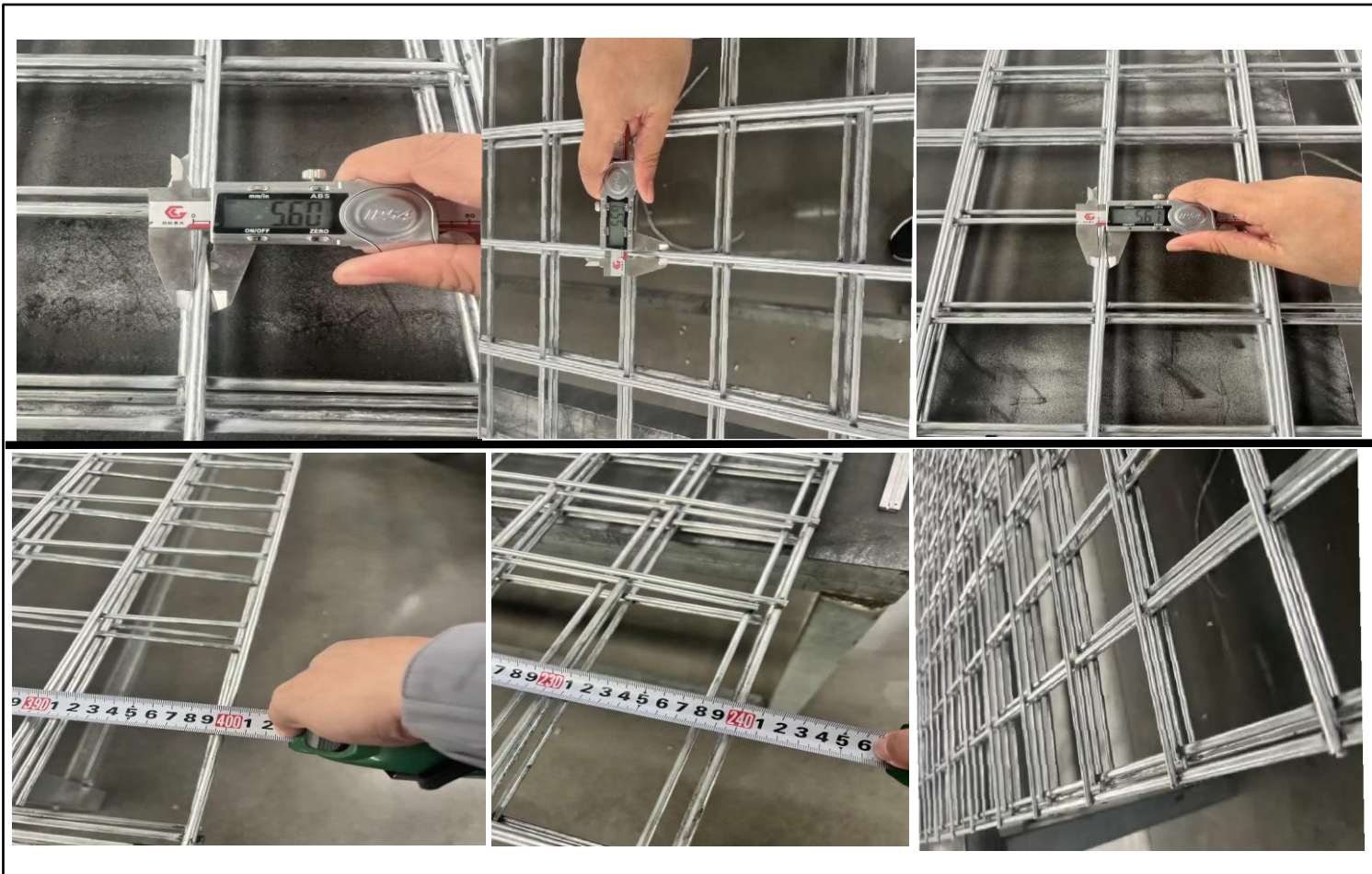

II. Wire Strength Test

Standard Requirements $\geq 10\text{kn}$

Inspection Results **11.44kn;11.63kn;11.57kn**

Conclusion **Qualified**



拉伸



拉伸



拉伸

试验批号	20260104	试验日期	2026-01-04
试验人		试样形状	圆材
尺寸(mm)	5.6	So(mm ²)	24.63
Lo(mm)		引伸计标距(mm)	300.0
平行长度(mm)	300.0	Lu(mm)	10.9
Fm (kN)	11.44	Rm(MPa)	464.39
Fel(kN)	10.14	最大力变形(mm)	6.7
最大变形(mm)	10.9	A(%)	
备注:			

试验批号	2026010401	试验日期	2026-01-04
试验人		试样形状	圆材
尺寸(mm)	5.6	So(mm ²)	24.63
Lo(mm)		引伸计标距(mm)	300.0
平行长度(mm)	300.0	Lu(mm)	9.9
Fm (kN)	11.63	Rm(MPa)	472.19
Fel(kN)	10.82	最大力变形(mm)	5.9
最大变形(mm)	9.9	A(%)	
备注:			

试验批号	2026010402	试验日期	2026-01-04
试验人		试样形状	圆材
尺寸(mm)	5.6	So(mm ²)	24.63
Lo(mm)		引伸计标距(mm)	300.0
平行长度(mm)	300.0	Lu(mm)	9.8
Fm (kN)	11.57	Rm(MPa)	469.59
Fel(kN)	10.71	最大力变形(mm)	5.8
最大变形(mm)	9.8	A(%)	
备注:			

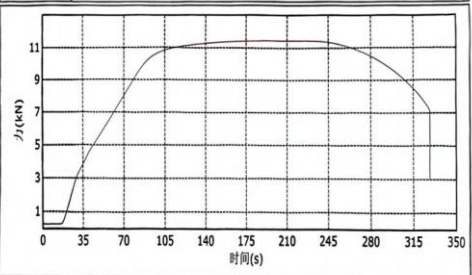

审核: _____ 批准: _____ 试验员: _____
打印日期: 2026-01-04

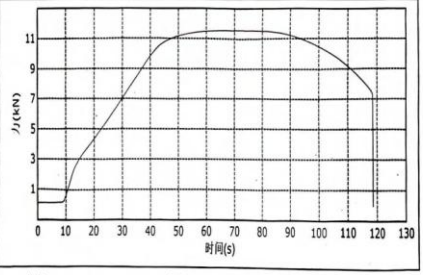

审核: _____ 批准: _____ 试验员: _____
打印日期: 2026-01-04

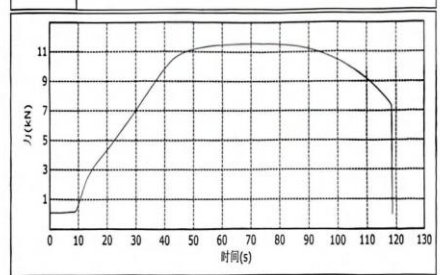

审核: _____ 批准: _____ 试验员: _____
打印日期: 2026-01-04

III. Weld Shear Test

Standard Requirements ≥ 8 kn

Inspection Results 10.56kn; 10.54kn; 10.38kn

Conclusion Qualified

拉伸



试验批号	2026010404	试验日期	2026-01-04
试验人		试样形状	圆材
尺寸(mm)	5.6	So(mm ²)	24.63
Lo(mm)		引伸计标距(mm)	300.0
平行长度(mm)	300.0	Lu(mm)	7.1
Fm (kN)	10.54	Rm(MPa)	427.77
Fel(kN)	3.75	最大力变形(mm)	6.4
最大变形(mm)	7.1	A(%)	

备注:

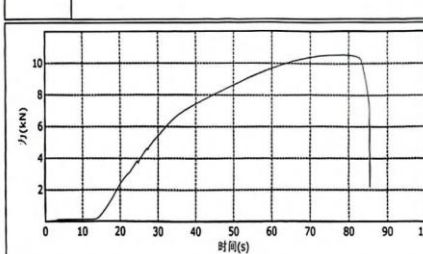

审核: _____ 批准: _____ 试验员: _____
打印日期: 2026-01-04

拉伸



试验批号	2026010403	试验日期	2026-01-04
试验人		试样形状	圆材
尺寸(mm)	5.6	So(mm ²)	24.63
Lo(mm)		引伸计标距(mm)	300.0
平行长度(mm)	300.0	Lu(mm)	6.2
Fm (kN)	10.56	Rm(MPa)	428.74
Fel(kN)	7.30	最大力变形(mm)	5.5
最大变形(mm)	6.2	A(%)	

备注:

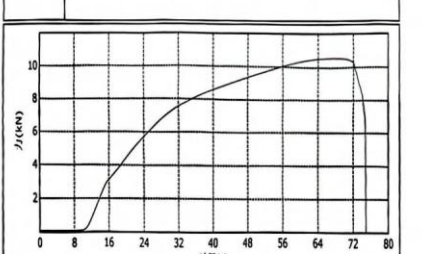

审核: _____ 批准: _____ 试验员: _____
打印日期: 2026-01-04

拉伸



试验批号	2026010405	试验日期	2026-01-04
试验人		试样形状	圆材
尺寸(mm)	5.6	So(mm ²)	24.63
Lo(mm)		引伸计标距(mm)	300.0
平行长度(mm)	300.0	Lu(mm)	7.3
Fm (kN)	10.38	Rm(MPa)	421.44
Fel(kN)	3.64	最大力变形(mm)	6.6
最大变形(mm)	7.3	A(%)	

备注:

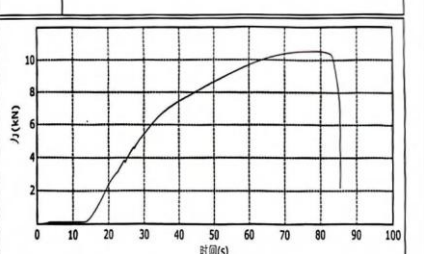

审核: _____ 批准: _____ 试验员: _____
打印日期: 2026-01-04

IV. PACKAGING

Standard Requirements	Packed in bundles of 25 units each.
Inspection Results	Total: 40 bundles. Each bundle is securely fastened with steel strapping.
Conclusion	Qualified

